

LOB[®] 600E

MULTIFONCTIONS NDA LOBE PUMPS

Destemmed grapes harvest, must, wine

CHARACTERISTICS

- Lobe pumps made of food grade hard Nitril rubber
- Low rotational speed
- Pump housing in 316 stainless steel precision
- Large range of flow from 3 000 to 70 000 l/h
- Electronic regulator
- Low oxygen dissolution (**a few µg/l**)
- Self-aspiration: 8 meters
- Rotational direction switch
- Continuous flow
- Pump trolley on stainless steel
- High pressure resistance (8 bars)
- High temperature resistance (from -10 °C up to 90 °C)
- Hygienic: easy cleaning and maintenance



DIMENSIONS / Weight: 280 kg

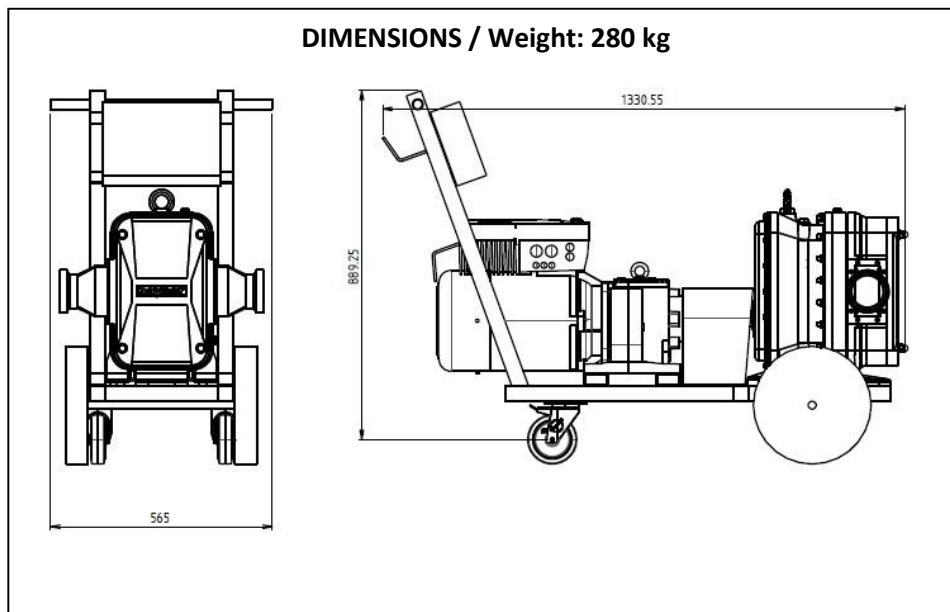

OPTIONS

- Radio control
- Pressure switch
- Tuning fork to detect liquids
- Pressure regulator

USES

- Transfer of destemmed grapes harvest, must with small solid particles, lees, juices, wines.
- Pumping over
- Filtration
- Bottling
- Able to empty pipes after transfers

FUNCTIONING PRINCIPLES

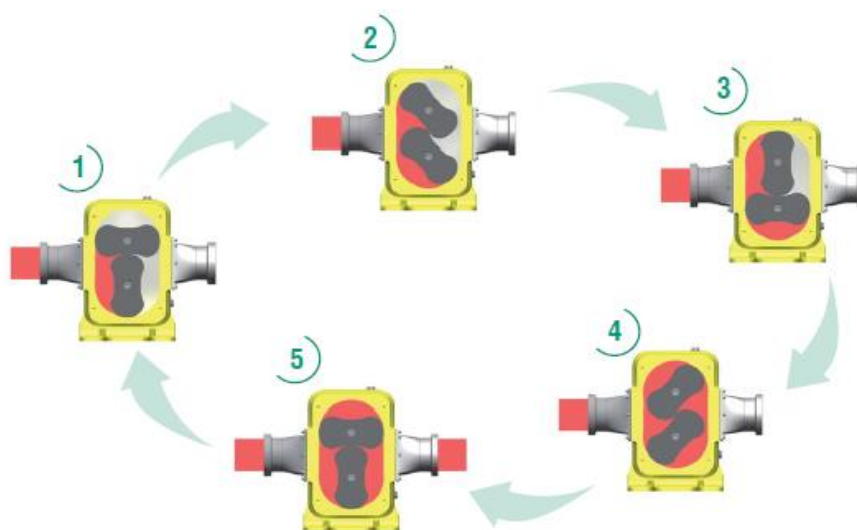

CURVES OF PERFORMANCE

Flow/Pressure

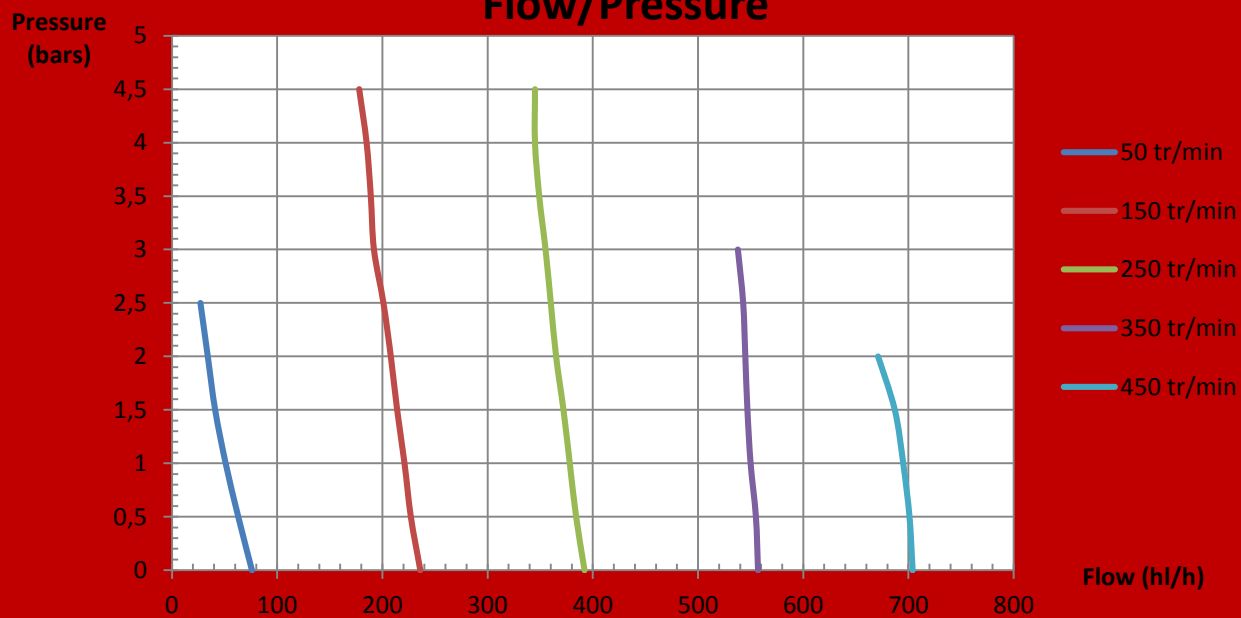

Rounds/min	Frequency (Hz)	Flow (hl/h)	Pressure (bars)	Intensity (Ampères)
50	9	27 à 76	0 à 2.5	7.8 à 10
150	26.9	178 à 236	0 à 4.5	8 à 14.2
250	44.8	345 à 392	0 à 4.5	8.1 à 14.4
350	62.8	538 à 557	0 à 3	7.1 à 15.7
450	80.7	671 à 704	0 à 2	10.4 à 15.6

TEST CONDITIONS

- Water at 10°C
- 12m and Ø 70 mm inhalation pipe
- 6m expulsion pipe
- Flow measuring with Oenodeb®50

