

LOB[®] 300E

MULTIFONCTIONS NDA LOBE PUMPS

Destemmed grapes harvest, musts, wines

CHARACTERISTICS

- Lobe pumps made of food grade hard Nitrile rubber
- Low rotational speed
- Pump housing in 316 stainless steel precision
- Large range of flow: up to 36000 l/h
- Passage of solid particles (\varnothing_{max} : 25mm)
- Electronic regulator
- Low oxygen dissolution (**a few $\mu\text{g/l}$**)
- Self-aspiration: 8 meters
- Rotational direction switch
- Continuous flow
- Pump trolley on stainless steel
- High pressure resistance (6 bar)
- High temperature resistance (from -10°C up to 90°C)
- Hygienic: easy cleaning and maintenance



DIMENSIONS / Weight: 220 kg

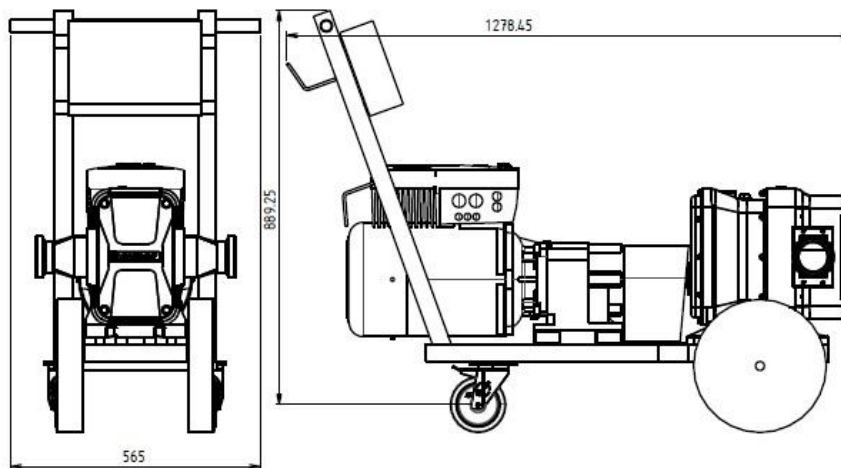

OPTIONS

- Radiocontrol
- Pressure switch
- Pressure regulator
- Tuning fork to detect liquids

USES

- Transfer of destemmed grapes harvest, musts with small solids particles, lees, juices, wines.
- Pumping over
- Filtration
- Bottling
- Able to empty pipes after transfers

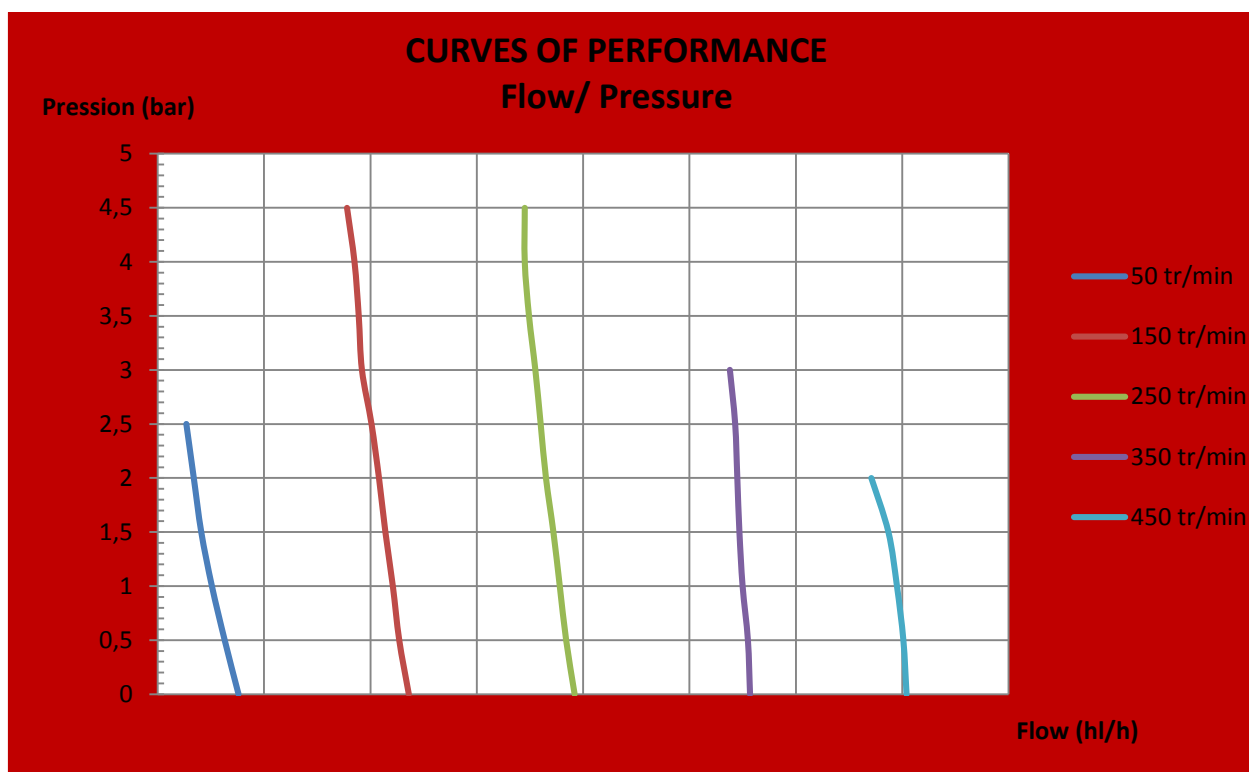
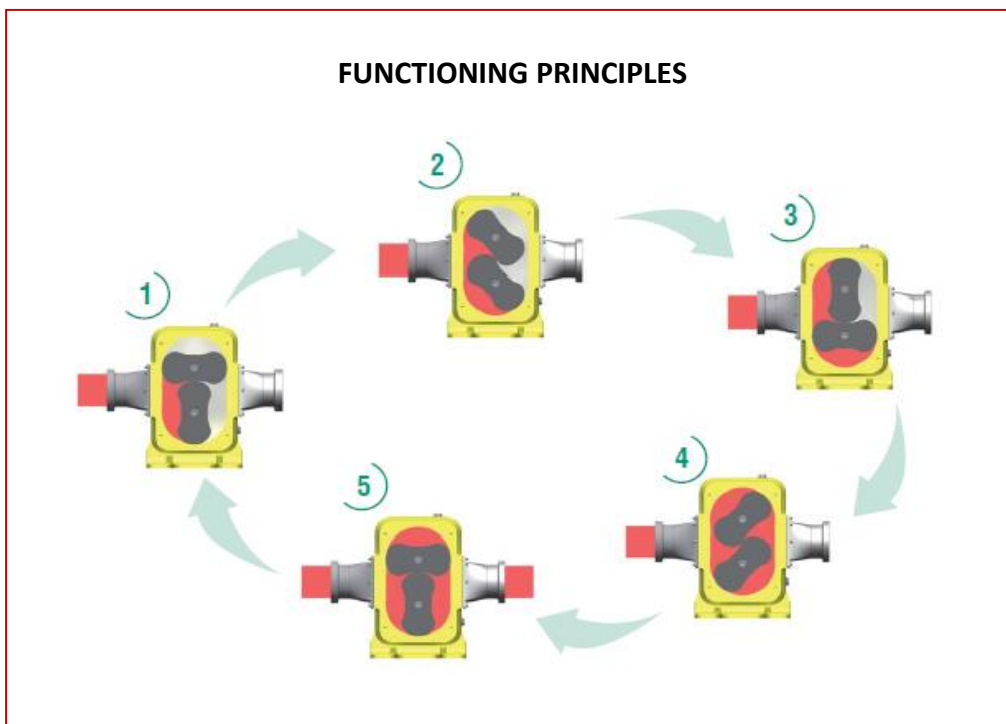

RPM	Frequency (Hz)	Flow (hl/h)	Pressure (bars)	Intensity (Amperes)
50	9	15 à 35	0 à 2.5	7.8 à 10
150	26.9	90 à 120	0 à 4.5	8 à 14.2
250	44.8	170 à 200	0 à 4.5	8.1 à 14.4
350	62.8	270 à 280	0 à 3	7.1 à 15.7
450	80.7	300 à 320	0 à 2	10.4 à 15.6

TEST CONDITIONS

- Water at 10°C
- 12m and \varnothing 70 mm inhalation pipe
- 6m expulsion pipe
- Flow measuring with Oenodeb®50

